

YAMAHA

COMBO ORGAN

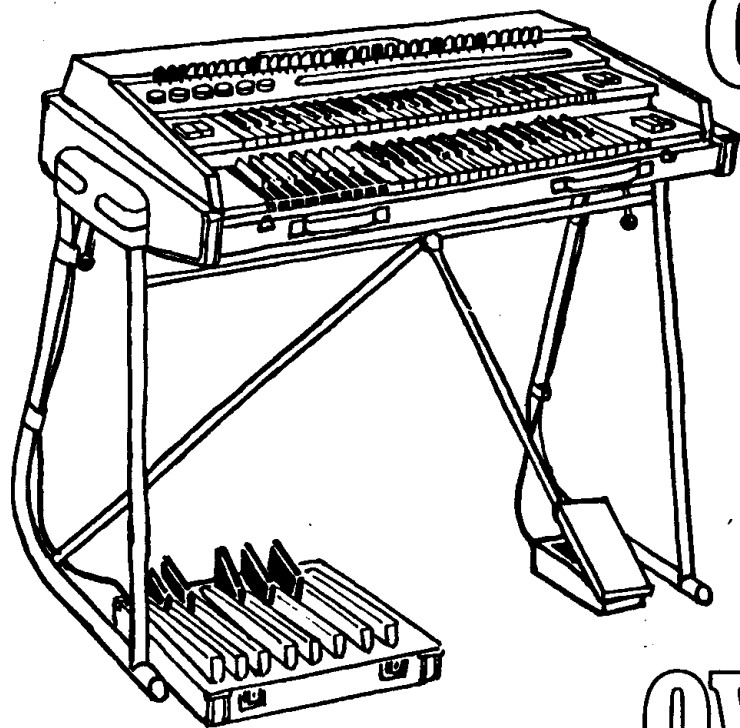

MODEL YC-45 D

OWNER'S MANUAL

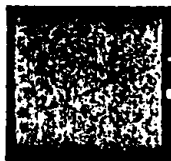

YAMAHA COMBO ORGAN YC-45D

OWNER'S MANUAL

CONTENTS

INTRODUCTION	2
ASSEMBLY	3
HERE IS YOUR YAMAHA COMBO ORGAN YC-45D ...	4
HOW TO PLAY YOUR YC-45D	6
1. Keyboards	6
2. Tone Levers	6
3. Effect Levers	9
4. Effect Controls	12
5. Effect Selectors	13
6. Other Fittings	15
CARE OF YOUR YAMAHA COMBO ORGAN	16
Caution	16
SPECIFICATIONS	17

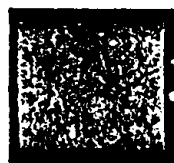

INTRODUCTION

Thank you for selecting the Yamaha YC-45D for your TWO-MANUAL combo organ! We hope you will read this manual carefully and will experiment with the organ's many special features, in order that a more complete understanding of its versatility will be yours.

The Yamaha Combo Organ Model YC-45D boasts practically every feature found in expensive console types, plus many extras for far-out arrangements. It includes a smashing range of 29 and swooping portamento manuals are complemented by full three-manual versatility from two preset selectors and the exclusive Yamaha fingertip keyboard touch controls, making this model the natural choice for the musician on his way to the top — or already there. And you get a full array of convenience extras, including pitch, master volume and bass volume controls, easy set-up and portability, decades-durable solid state circuitry. The above mentioned controls and features will be explained in more detail in the following pages.

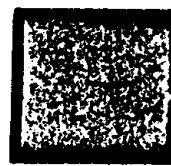
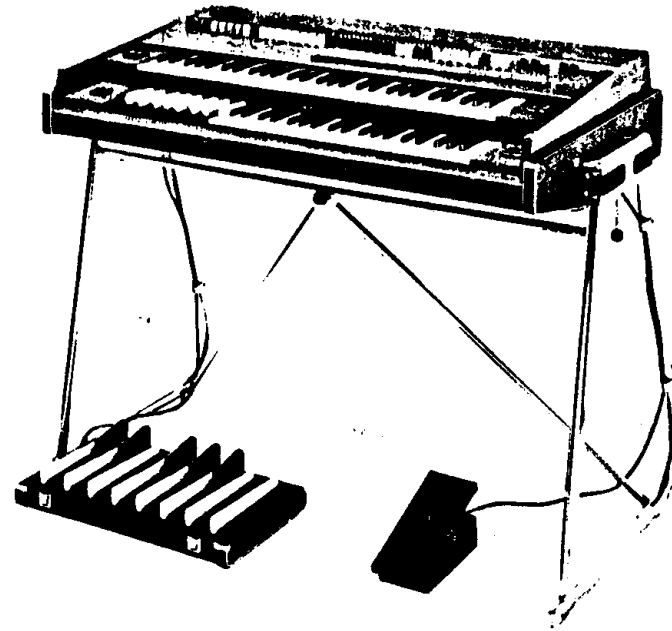

ASSEMBLY

1. Remove the 2 legs from the vinyl bag and connect them with screw **(A)**.
2. Install the leg assembly under the main body of the unit and secure them tightly with the four screws **(B)**.
3. Open the cover by releasing catch **(C)**. The expression pedal and power supply cord can then be removed.
4. When standing the unit upright, balance it by adjusting balancing screw **(D)**.
5. The inclination angle of the keyboard can be adjusted to the desired angle by loosening the two levers **(E)** at both sides of the unit and, after adjusting the keyboard to the desired inclination, lock it in place by tightening these levers. The keyboard can be rotated 120° from the vertical to downwards slope. You have added freedom to play comfortably in any position.

Completely disassembled, parts stored, and over in place, your Yamaha Combo Organ Model YC-45D becomes a convenient, portable unit as shown.

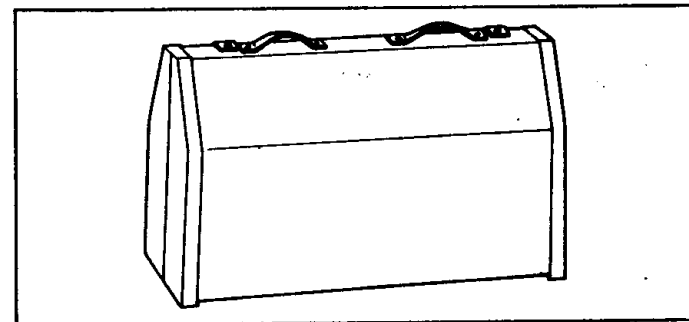
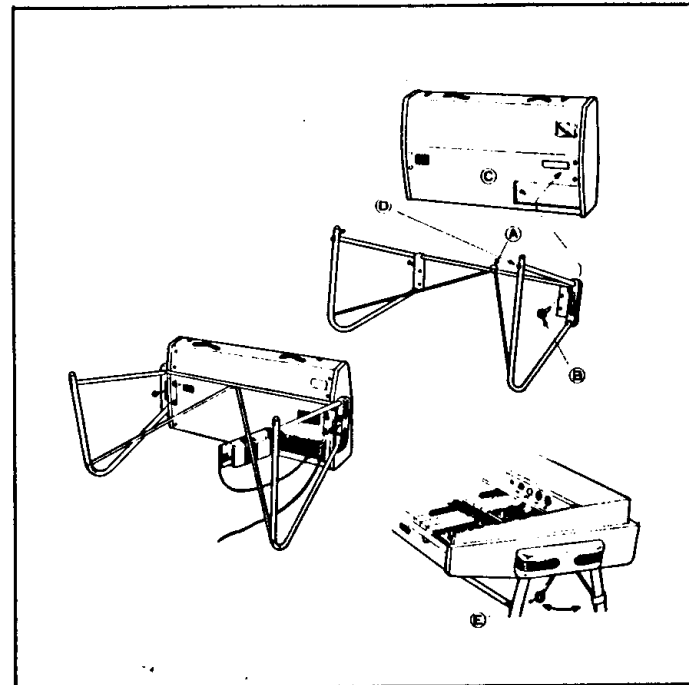

HERE IS YOUR YAMAHA COMBO ORGAN YC-45D

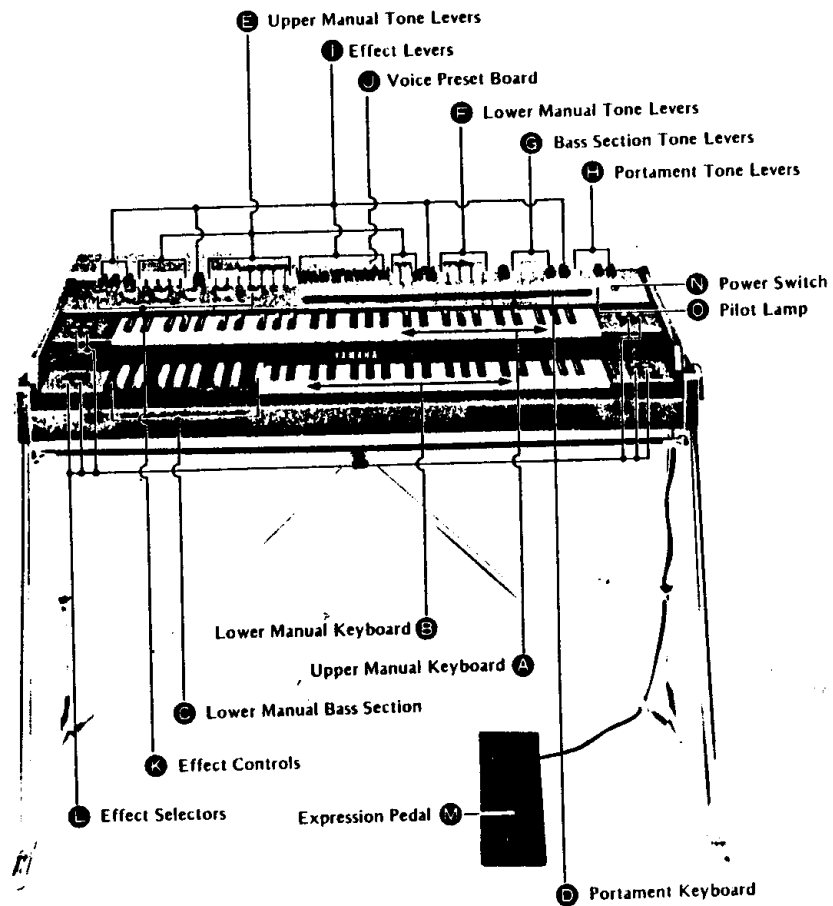

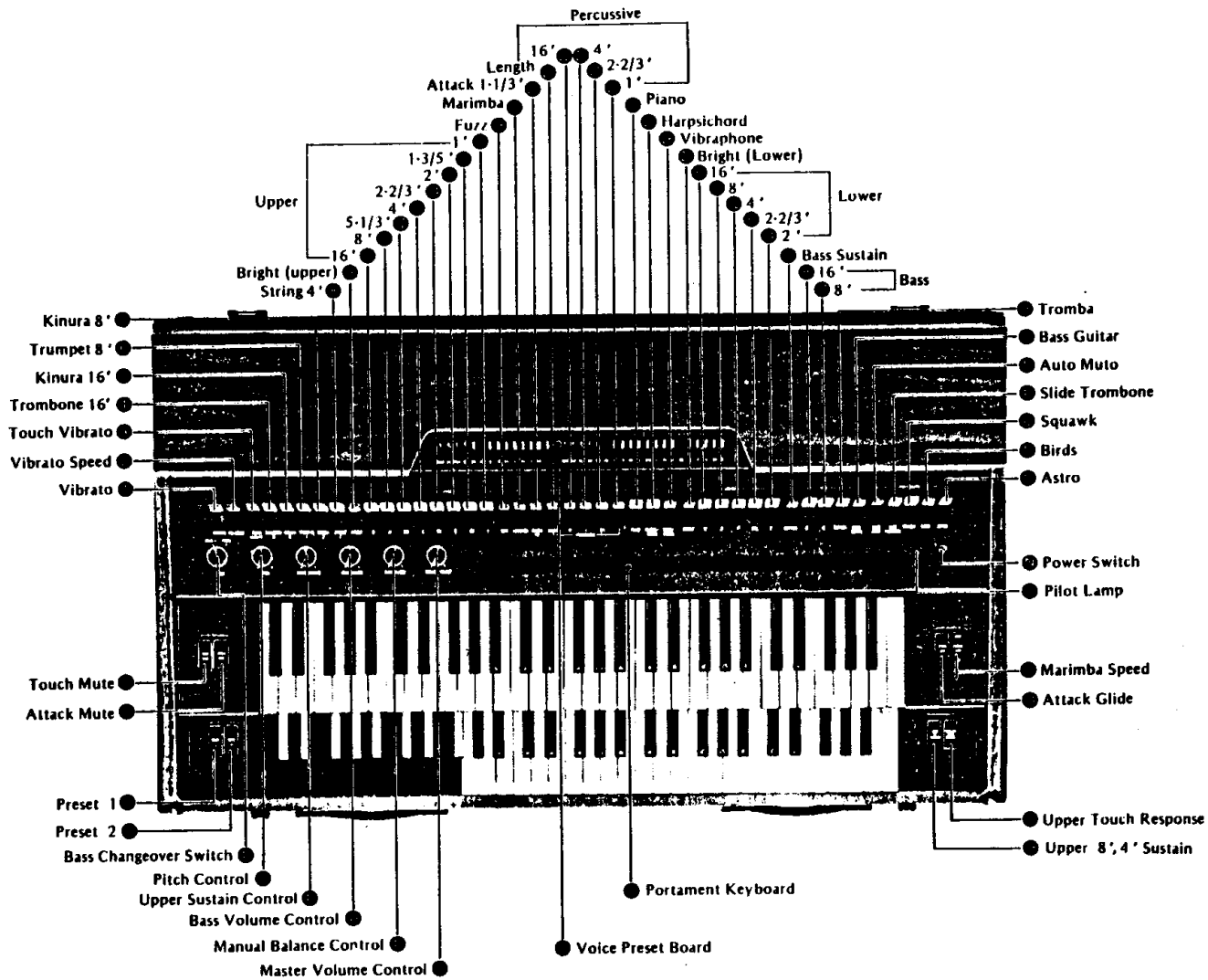

HOW TO PLAY YOUR YC-45D

1. Keyboards

The YC-45D keyboards are as follows:

Upper Manual	Ⓐ	61 keys (C~c ₄)	5 octaves
Lower Manual	Ⓑ	61 keys (C~c ₄)	5 octaves
Manual Bass	Ⓒ	19 keys (C ₁ -F#)	1½ octaves
Pedal Bass	(optional)	13 keys (C ₁ -C)	1 octave
Portamento	Ⓓ	c ₁ ~c ₄	3 octaves

The manual keys are made of durable material, designed for years of beautiful appearance and playing ease. The manual keys work with the tone levers for tone color selection. The 19 bass keys on the extreme left end of the lower manual, identified by reversed colors, become a manual bass section

when the Bass Changeover Switch (Manual/Pedal) ⑩ is set for Manual Bass. When this switch is set for Pedal Bass and the optional pedals are attached, they work as the bass section. In either case bass tones are set by the Manual Bass or Pedal Bass tone levers. When the pedal bass is used (with the switch set to Pedal Bass), the above-mentioned 19 lower manual keys become a regular extension of the lower manual. The portamento manual provide razor-sharp tones for glides, comic effects, etc. It has been specially designed for easy playing; its pitch corresponds at any point to the upper manual key directly below.

2. Tone Levers Ⓔ Ⓕ Ⓖ Ⓗ

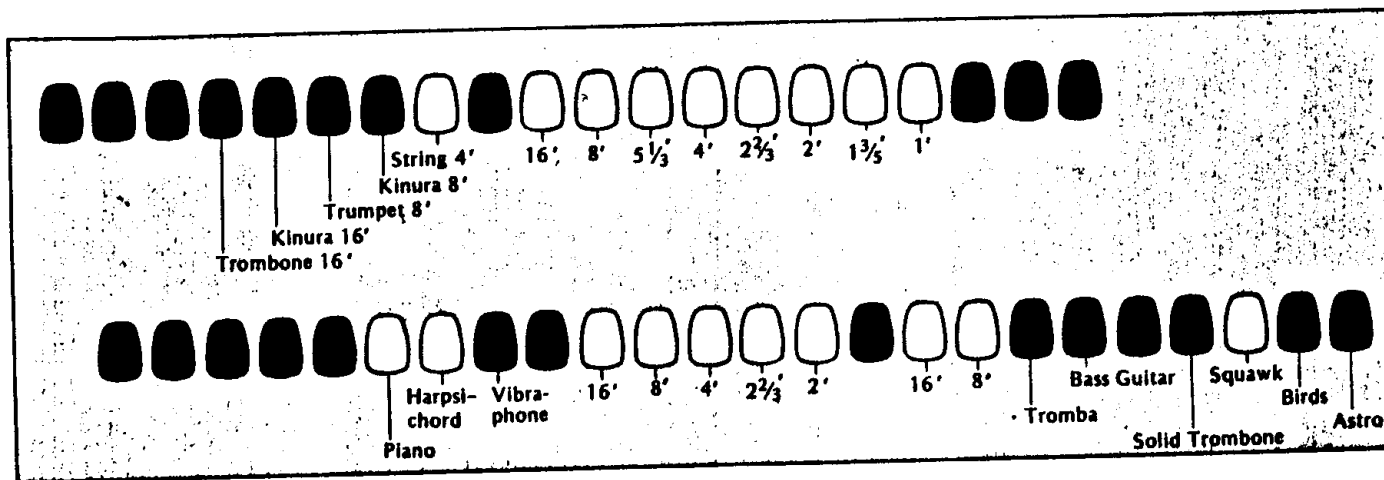

There are groups: one group for the Upper Manual (16 voices), one for the Lower Manual (5 voices), one for the Manual or Pedal Bass (4 voices) and one for the Portamento (4 voices).

Exclusive Yamaha Tone Lever System

This unique system provides much more variety than the conventional on/off system of organ stops. Here each voice has its own lever, which slides continuously from off to full for unlimited variety of tonal shadings, a wider expressive range for the keyboard master. For the beginner, or the player in a hurry, there are two click-stops along the way, at 1/3 and 2/3 full settings. The click-stops can be clearly felt, even though they do not hamper the continuous slide control, and they can be used to reset tonal combinations with mathematical precision. The YC-45D provides this world-famous system to satisfy every talent and playing style. Full mastery of tone lever use is the most important point in developing your own style, so make it a practice to recreate tones you have heard and like, as well as creating your own. Also note that the Upper, Lower, Bass and Portamento tone lever settings will have a direct effect upon the relative balance of these four sections.

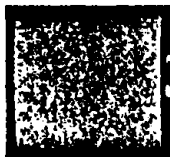
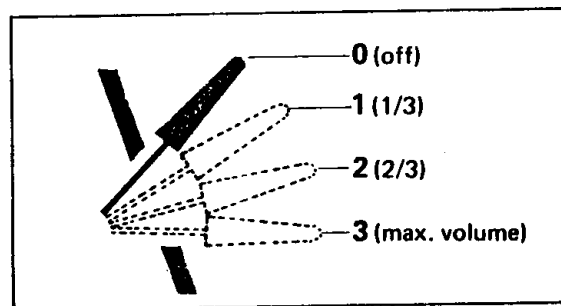

Harmonics

Tone levers provide several harmonics (8', 16', $2\frac{2}{3}'$, etc.); the 8' levers are "fundamentals", which means they have the same pitch as the written note. The others are called "harmonics" because they are at certain intervals above or below

the written note. For purposes of classification, harmonics are generally divided into "consonants" (at octave intervals from the fundamental) and "dissonants" (separated by a third or fifth from the fundamental). An example will show what

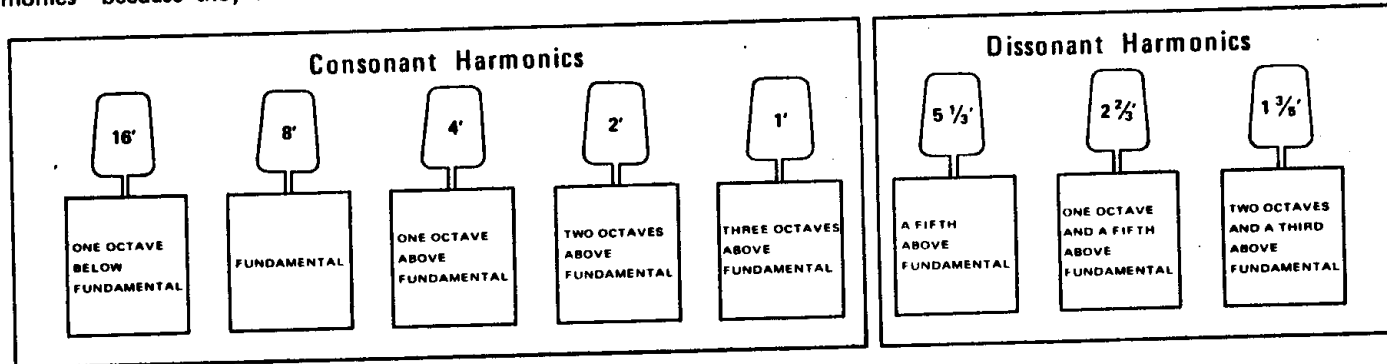

this means in playing. If you press middle C (called "c₁" in musical terminology) and set a 4' tone lever, you will get the same note as you would by pressing c₂ (an octave above c₁) with an 8' tone lever. This means, of course, that the YC-45D's range is really much wider than the actual keyboard; using the 16' lever, for example, will extend its scope down to c₁ (see illustration). Similarly, the 1' lever raises the tone three octaves. Here, however, there is a limitation: the highest note YC-45D can produce is b₅. Any notes above this will actually sound in the fifth octave above middle C. This unavoidable limitation is nothing to worry about, for the YC-45D's actual range is still more than enough for the most demanding organist. The use of the harmonic levers is not to extend the range of pitches, but rather to create richer full-bodied tonal combinations within the normal playing range.

They are the spices that flavor the various fundamentals, suiting them to the mood of each selection.

Piano 26

This is a factory-set 8' tonal blend. The tone is combined with a special attack effect that decays rapidly even when the key is held down for an incredibly realistic piano sound. This on/off lever automatically cancels all other Upper Manual voices and effects, except Harpsichord, Vibraphone, Attack Glide, and Upper Sustain Touch Response.

Harpichord 27

Also an on/off factory-set 8' tonal combination. Added attack and percussive effects complement the sharp blend of string voice. This lever cancels all Upper Manual voices and effects except Vibraphone, Attack Glide, Upper Sustain and Touch Response.

Vibraphone 28

This is the third on/off factory-set special 8' tone to help make the YC-45D so unique. Here the basic pitch is accented by a $1\frac{1}{3}$ ' attack and percussive effects at the beginning of each note. This lever cancels all Upper Manual voices and effects except Attack and Glide and Touch Response.

Tromba 38

Provides an attack and decay on all bass notes when this voice is used. The tone decays more rapidly when the key is depressed.

Bass Guitar 39

Provides an attack and decay on all bass notes when this voice is used. Begins to decay as soon as the key is depressed.

3. Effect Levers 1

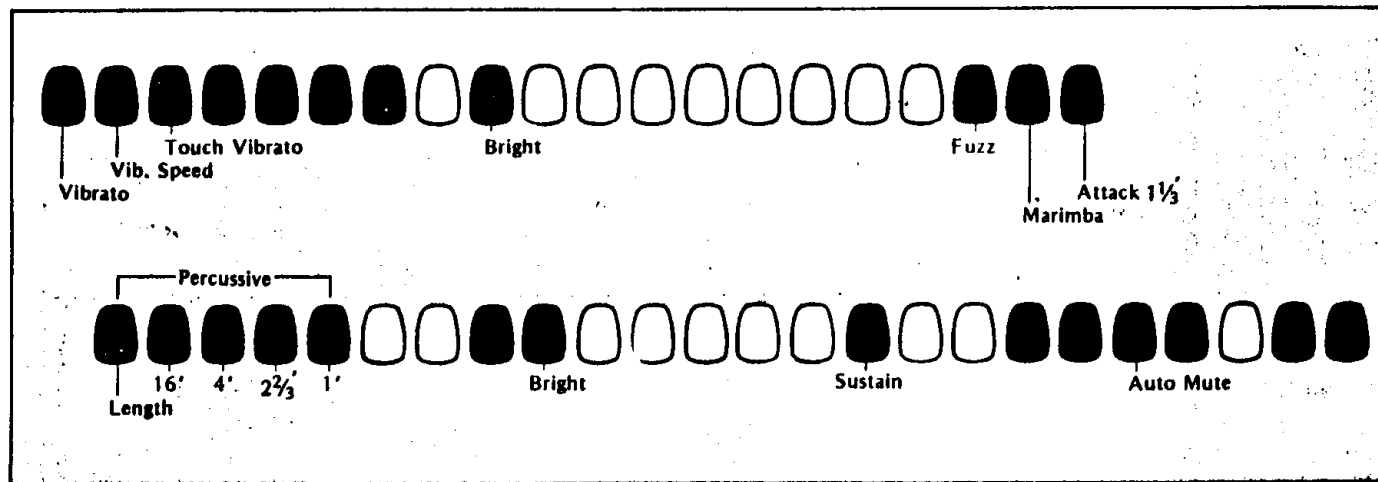

The effect levers ● of the YC-45D provide a wide range of tonal effects which add to the variety of possible combinations. These levers have the same operation as the tone levers and allow the organist to vary the depth or speed of their effects according to their stop positions as illustrated. All effects on the Upper Manual (except Attack Glide and Touch Response) are cancelled by the Piano, Harpsichord and Vibraphone levers.

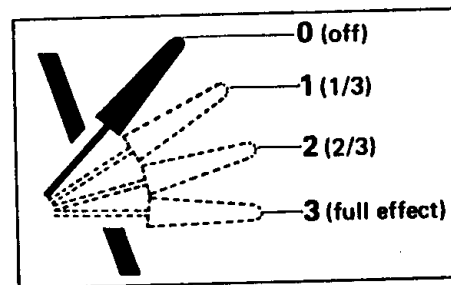

Vibrato ①

The use of vibrato increases the emotional quality of the tone and adds a brisk and lively air to passages of relative simplicity. Its depth is controlled by this lever.

Vibrato Speed ②

Used in concert with the Vibrato lever, it controls the oscillating speed of the vibrato, which increases as it is pulled down.

Touch Vibrato (Upper Manual) ③

This exclusive Yamaha effect lets you play with the same emotion in your fingers as a violinist. When the middle lever shown in the photograph is pressed, the lateral vibration of the finger on the key is transmitted as a warm vibrato. What's more, this key is continuously variable, so that you can adjust this effect's intensity to suit any mood, matching vibrato

nuances to any selection or passage. This effect is particularly dramatic when used with a single voice which forms the melodic line. It can be used in conjunction with the Vibrato lever, but if that lever is set to full it will override the Touch Vibrato.

Upper Percussive ⑴ ⑵ ⑶ ⑷ ⑸

Changing the beginning of some or all notes can do wonders for lively selections. The YC-45D really shines here, thanks to a variety of percussive effects. Any combination of the special popping 16', 4', 2²/₃' and 1' percussive drives can be smoothly blended into all upper tones with variable levers, and there is an extra one to control the decay length of these effects. Each note should be played cleanly; slurred notes will diminish the percussive effect. If a second note is pressed while the first is still held down, the percussive effect will be lost.

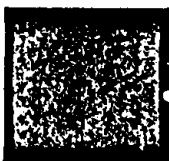

Fuzz 18

Adds a husky overtone to all Upper Manual voices except Piano, Harpsichord and Vibraphone. In spite of its comic possibilities, this effect can often add to the emotion of serious and lyrical passages.

Bright (Upper 9 , Lower 29)

On the Upper Manual this effect covers all the white keys (16' to 1'), and on the Lower Manual from 16' to 2'. Each lever is continuously variable to provide a hard string-like tonal balance or any shade down to a soft flute-like effect.

Attack 1-1/3' 20

Adds emphasis to the beginning of each Upper Manual note — at a $1\frac{1}{3}'$ harmonic. An outstanding feature of this unique effect is that it works on succeeding notes even if the first is held down.

Marimba 19

This lever provides an alternating 8'/4' tonal combination. The normal oscillation speed can be almost doubled by using the Marimba Speed selector, and further variation is possible when combined with various Upper Sustain settings.

Auto Mute 10

Automatically mutes the Portamento Manual for a softer version of all four voices.

Bass Sustain 35

You can tailor your bass to perfectly match the mood of the music. Release the note, the sound lingers on for precisely as long as you want, thanks to this continuous controls.

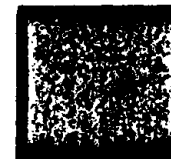

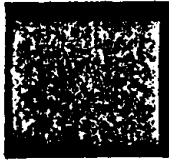

4. Effect Controls

Manual/Pedal Bass Switchover 45

When set to Manual, bass tones will come from the C-f# keys on the Lower Manual. When set to Bass, bass tones will come from the pedalboard and the reverse color Lower Manual keys will serve as a 19-note extension of that manual. Bass pedalboard (Model BP-1) is available as an optional accessory.

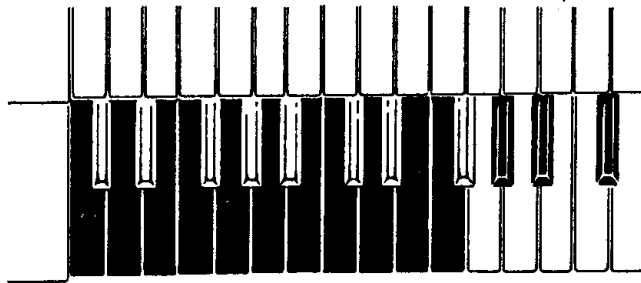

Reversed color section ©

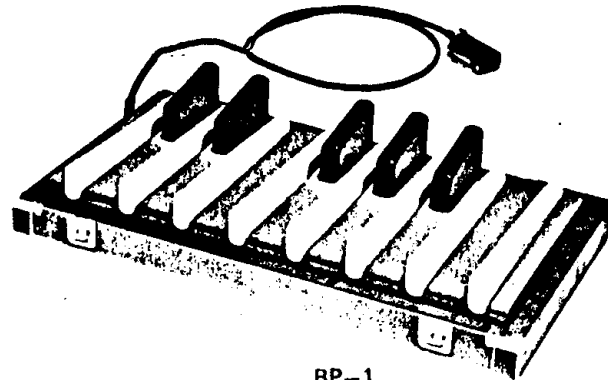

BP-1

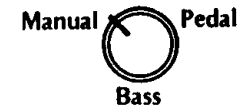

Reversed color manual keys become bass section (pedals do not function even if connected).

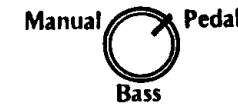

Pedals become bass section (reversed color manual keys become extension of lower manual).

Bass Volume 46

The maximum setting of this control will result in bass tones ten times louder than when it is set at minimum. Continuous adjustment possible.

Pitch Control 46

This control allows you to vary the pitch as much as 20 cents above and 3.5 cents below standard (indicated by the dot). Use it to "tune" the YC-45D to other instruments.

Master Volume 50

This knob determines the YC-45D's maximum volume with the expression pedal fully depressed. Use it to control the expression pedal's volume range.



Manual Balance 49

Governs the relative strength of Upper and Lower Manuals. This control is normally left in the center position, but can be used to strengthen one manual. It can serve to accentuate an Upper Manual melody in relation to Lower Manual accompaniment (turn to the right), or Lower Manual tones (turn to the left).

Upper 8', 4' Sustain

Sustain prolongs each note (Upper: 8', 4' and Marimba only) lets you create sharper or more slurred tones according to the selection. This effect can be used together with several effect levers (except Percussive 4'), Attack, to accentuate their flavor (except Percussive 4').

The upper manual sustain effect is in the form of a two-way control with the control 47 and linked to the sustain selector 52.

50 Their respective functions may be outlined as follows:

5. Effect Selectors

Touch Mute 51

Works like touch vibrato on all Upper Manual keys (except Attack 1 1/3 and percussive). Instead of changing the timbre of the note, touch mute translates the lateral vibration of the fingers into a change in tone color. You can get more interesting voice, using touch mute together with Fuzz.



Sustain Control : 47

This control is used to set the maximum possible sustain, and may be set before or during the performance. It is turned fully to the left for no sustain, and progressively to the right to lengthen the effect (except Piano, Harpsichord).

Sustain Selector : 52

This selector is used before or during the performance to choose the sustain effect.

Attack Mute 52

Provides a subtle tonal effect at the beginning of each Upper Manual note. Works on successive notes, even if the first is held down. Cancels Touch Mute.

Attack Glide 54

When this selector is set all Upper Manual notes sound slightly lower (approximately 90 cents) than their true pitch when the key is pressed, then return to true pitch within approximately one second. To use this effect, be sure to play each note cleanly; if a key is depressed before the one before it is released, there will be no glide on that note.

Touch Response 56

When this tablet is switched on a special fingertip control is available to all upper 8' and 4' tones, as well as Marimba, Piano and Harpsichord. The harder you strike each key, the louder the sound. With this response on, a very soft keyboard touch will drown out all other tones and accentuate Piano or Harpsichord.

Voice Preset 1 55, 2 56

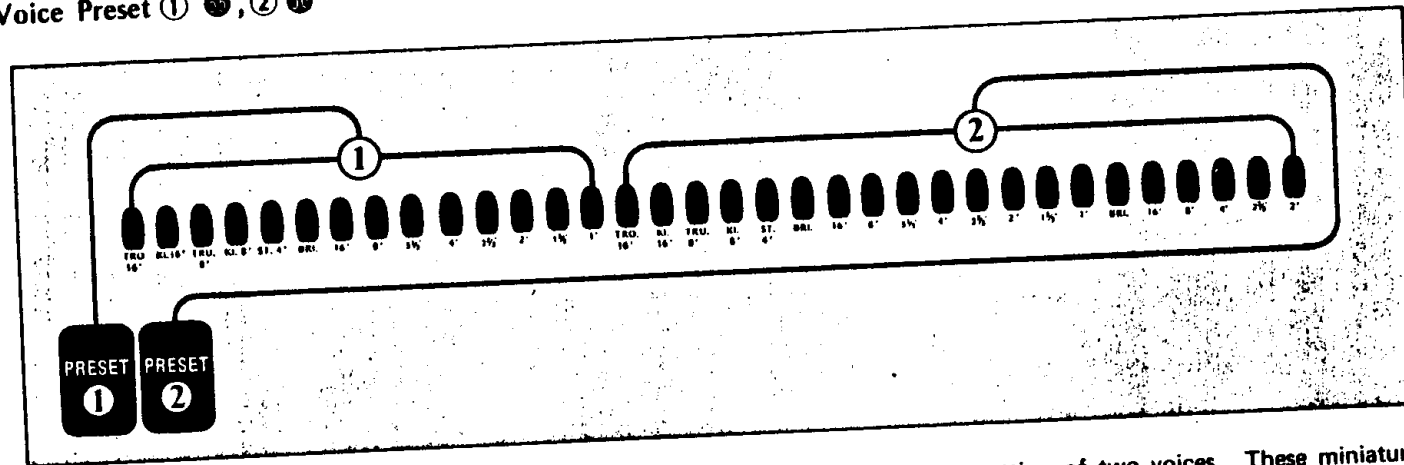

This fig shows the Voice Preset Board 55. The numbers 1 and 2 indicate the two rows of miniature tone and effect levers

which allow the presetting of two voices. These miniature levers are also continuously variable like the control panel

levers duplicating that unique feature, and are arranged in exactly the same order for convenience in setting. When Preset Selectors ① 5b and ② 5b are both used at the same time, ② will take priority over ①.

Marimba Speed Slow/Fast 5b

The Marimba Speed lever permits selection of a marimba effect of either about 5 HZ (Slow) or about 9 HZ (Fast).

6. Other Fittings

Power Switch N & Pilot Lamp O

Pushing the Power Switch once turns it on, pushing it again turns it off; pushing it once more turns it on again. The Pilot Lamp lights to indicate the switch is on.

Expression Pedal M

Depress it to increase the volume while playing.

Output Jack

Feeds the signal to your amplifier system.

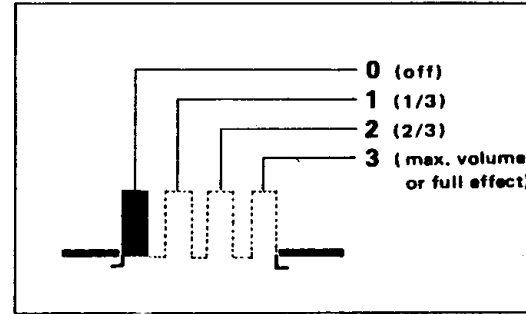

Optional Pedalboard Socket

Please connect the cable from pedal keyboard unit to "Optional Pedalboard Socket" to control the bass tone with pedal keyboard. Be sure to set Bass Changeover Switch for "Pedal".

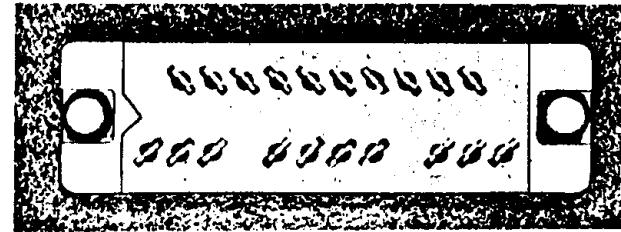

CARE OF YOUR YAMAHA COMBO ORGAN

In general, you should treat your Combo Organ with the same care you would give any fine musical instrument. However the following points are suggested to assure optimum enjoyment.

1. When you have finished playing, be sure to turn off the power switch.
2. In order to clean manual keys, tabs, etc., use a damp cloth. Never apply household cleaners or solvents such as alcohol, as they may damage the plastic materials used.
3. If your Yamaha Combo Organ becomes inoperative or does not function properly, first follow this simple step-by-step check list before calling for service.
 - (1) Make certain that the line cord is plugged into a live AC outlet. Make sure the wall receptacle is not faulty. (Hum from the speaker may be reduced by reversing the line cord plug in the wall outlet.)
 - (2) Be sure the "ON-OFF" Power Switch is on. Pilot Lamp will light to indicate this.
 - (3) Check the input cord for loose connections or shorts.
 - (4) Make sure the master volume control is turned up at least part way and that the swell shoe is firmly attached and depressed. At least one tone volume lever must be on, and the balance lever set to favor that section of voices.
4. If, after checking the above points, the instrument still seems to be out of order, contact your Yamaha Service Agent. The Yamaha Combo Organ uses IC's and other solid state devices so, do not attempt to touch or otherwise interfere with the circuits or internal elements of this instrument.

CAUTION VOLTAGE ADJUST

Before you plug in the AC supply, please check that the voltage selector is set to your local current. If not properly set, pull out the socket and reinsert it to the correct voltage position.

Voltage settings: 100, 110, 117, 125, 220, 240 V
Models for the U.S., Canada, England and North Europe are properly preset before shipment.

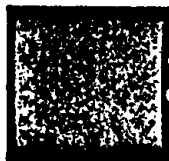
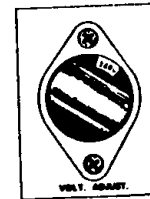

SPECIFICATIONS

KEYBOARDS

Upper Manual	61 keys (C ~ c ₄)
Lower Manual	61 keys (C ~ c ₄)
Manual Bass	19 keys (C ₁ ~ F [#])
Pedal Bass	13 keys (C ₁ ~ C)
Portamento	C ₁ ~ C ₄

TONE LEVERS

Upper Manual	16', 8', 5-1/3', 4', 2-2/3', 2', 1-3/5', 1'
	Trombone 16'
	Kinura 16'
	Kinura 8'
	Trumpet 8'
	String 4'
	Piano
	Harpichord
	Vibraphone
Lower Manual	16', 8', 4', 2-2/3', 2'
Manual/Pedal Bass	Bass 16'
	Bass 8'
	Tromba
	Bass Guitar
Portamento	Slide Trombone
	Squawk
	Birds
	Astro

EFFECT LEVERS

Upper & Lower	Vibrato
	Vibrato Speed
Upper	Touch Vibrato
	Fuzz
	Bright
	Marimba
	Attack 1-1/3'
	Percussive Length
	Percussive 16'
	Percussive 4'
	Percussive 2-2/3'
	Percussive 1'
Lower Manual	Bright
Portamento	Auto Mute
Bass	Bass Sustain

EFFECT CONTROLS

Bass Changeover Switch (Manual/Pedal)
Pitch Control
Upper Sustain (8', 4', Marimba)
Bass Volume
Master Volume
Manual Balance

EFFECT SELECTORS

Upper Manual	Percussive
	Touch Mute
	Touch Response
	(8', 4', Marimba, Piano, Harpsichord)
	Attack Mute
	Attack Glide
	Preset 1 (Upper)
	Preset 2 (Upper + Lower)
	Marimba Speed (Slow/Fast)

OTHER FITTINGS

Power Switch
Expression Pedal
Output Jack
Optional Pedalboard Socket

CIRCUITRY

Solid State (incl. ICs)

POWER CONSUMPTION

30 Watts

DIMENSIONS (WxHxD)

111 x 97 x 65cm (44 x 38 x 26")

WEIGHT (with legs)

60 kg (132 lbs.)

FINISH

American Walnut with Grey
Leatherette Siding

OPTIONAL ACCESSORY

Bass Pedalboard (BP-1)

FOR THE BRITISH STANDARD MODELS

As the colours of the wires in the mains lead of the apparatus may not correspond with the coloured markings identifying the terminals in your plug proceed as follows. The wire which is coloured GREEN-and-YELLOW must be connected to the terminal in the plug which is marked by the letter E or by the safety earth symbol \perp or coloured GREEN or GREEN-and-YELLOW. The wire which is coloured BLUE must be connected to the terminal which is marked with the letter N or coloured BLACK. The wire which is coloured BROWN must be connected to the terminal which is marked with the letter L or coloured RED.

IMPORTANT:

The wires in the mains lead are coloured in accordance with the following code.
 GREEN-and-YELLOW Earth
 BLUE Neutral
 BROWN Live

WARNING:

This apparatus must be earthed.

Specifications subject to change without notice.